

# ClearOne®

## UNITE® 260 Pro Camera



## ClearOne® Contacts

### Headquarters

5225 Wiley Post Way Suite 500  
Salt Lake City, UT 84116

### Sales

**Tel:** +1.801.975.7200  
[sales@clearone.com](mailto:sales@clearone.com)

### Headquarters

**Tel:** +1.801.975-7200

### Technical Support

**Tel:** +1.801.974.3760  
[videotechsupport@clearone.com](mailto:videotechsupport@clearone.com)

## Notices

©2024 ClearOne, Inc. All rights reserved.  
Information in this document is subject to change without notice.  
Document: DOC-0571-001v1.0 July 2024

## Contents

<b>FCC Notices.....</b>	<b>iii</b>
<b>1. Safety Precautions .....</b>	<b>1</b>
<b>2. Packing List .....</b>	<b>1</b>
<b>3. Product Information .....</b>	<b>2</b>
<b>4. GUI Settings .....</b>	<b>11</b>
<b>5. Web Settings .....</b>	<b>15</b>
<b>6. Record Settings .....</b>	<b>22</b>
<b>7. Serial Command Control .....</b>	<b>23</b>
<b>8. Troubleshooting .....</b>	<b>25</b>

## FCC Notices (Class A)



This device complies with Part 15 of the FCC Rules. The operation is subject to the following two conditions: (1) this device may not cause harmful interference, and (2) this device must accept any interference received, including interference that may cause undesired operation



**Note:** This equipment has been tested and found to comply with the limits for a Class A digital device, pursuant to Part 15 of the FCC Rules. These limits are designed to provide reasonable protection against harmful interference in a residential installation. This equipment generates uses and can radiate radio frequency energy and, if not installed and used in accordance with the instructions, may cause harmful interference to radio communications. However, there is no guarantee that interference will not occur in a particular installation. If this equipment does cause harmful interference to radio or television reception, which can be determined by turning the equipment off and on, the user is encouraged to try to correct the interference by one or more of the following measures:

- Reorient or relocate the receiving antenna.
- Increase the separation between the equipment and receiver.
- Connect the equipment into an outlet on a circuit different from that to which the receiver is connected.
- Consult the dealer or an experienced radio/television technician for help.

## Class A ITE

Class A ITE is a category of all other ITE which satisfies the class A ITE limits but not the class B ITE limits. Such equipment should not be restricted in its sale, but the following warning shall be included in the instructions for use:

### **Warning:**

Operating this equipment in a residential environment may cause radio interference.

## European Community Compliance Statement (Class A)



This product is herewith confirmed to comply with the requirements set out in the Council Directives on the Approximation of the laws of the Member States relating to Electromagnetic Compatibility Directive 2014/30/EU.

## Copyright

All contents of this manual, whose copyright belongs to Clearone corporation cannot be cloned, copied or translated without the permission of Clearone corporation.

## 1. Safety Precautions

- During the installation and operation, all electrical safety regulations of the country and region of use must be strictly observed.
- Please use the power adapter that comes standard with this product.
- Do not connect multiple devices to the same power adapter (exceeding capacity of the adapter may generate excessive heat or cause fire).
- Do not rotate the camera by hand, otherwise it may cause mechanical failure.
- When installing this product on a wall or ceiling, make sure the device is installed securely and there are no obstacles within the rotation range; Do not power on until all installation steps are completed.
- To avoid heat build-up, please keep adequate ventilation around the device.
- If the device smokes, smells, or makes noises, please turn off the power and unplug the power cord immediately, and then contact the dealer.
- This device is not waterproof, please keep the device dry.
- This product has no user serviceable parts, damage caused by disassembly by the user is not covered by the warranty.

### Notice

Specific frequencies of electromagnetic field may affect the image of the camera!

## 2. Packing List

No.	Product Description	Quantity
1	Camera	1
2	Power Adapter	1
3	RS232 Cable	1
4	USB Cable	1
5	Remote Control	1
6	User Manual	1

## 3. Product Information

### 3.1 Features

- **Full Function USB Interface**

Full featured USB Type-C interface, compatible with USB3.0 and USB2.0, supports audio and encoding output, supports UVC 1.1 protocol.

- **4K UHD**

The new high-quality 1/1.8-inch UHD CMOS sensor with 8.42 million effective pixels enables ultra-high-resolution images up to 4K (3840x2160), downward compatible with 1080P, 720P and other resolutions.

- **AI Tracking and Framing**

Built-in artificial intelligence processor, using deep learning algorithms. AI tracking can achieve smooth tracking of the human body no matter where the face is, which is perfect for object tracking scenarios in lectures, presentations and other activities. AI framing with automatic zoom and pan/tilt rotation functions, places participants at the best size and position in the video.

- **HDMI 1.4b**

Supports HDMI 1.4b and can output 4K raw video directly without compression.

- **20x Optical Zoom**

Exclusively customized high-quality with 8 million pixel sensor and ultra-wide-angle-lens. The horizontal field angle of view is up to 60.7°.

- **Low Illumination**

The new CMOS image sensor with ultra-high SNR effectively reduces image noise under low illumination. The application of 2D and 3D noise reduction algorithms greatly reduces image noise even under the condition of ultra-low illumination. It keeps the picture clean and clear with an image SNR as high as 55 dB.

- **PoE**

The Ethernet port supports PoE. Power, control, video, and audio can all be carried on a single network cable.

- **Remote Control**

The camera can be controlled remotely through the RS232, RS485, network or USB port.

- **Multiple & Complete Interfaces**

HDMI, USB3.0 and network interfaces can output 4K video simultaneously.

- **Multiple Power Supply Modes**

Simultaneously supports a DC 12V power adapter and a PoE power supply.

### 3.2 Product Specifications

No.	Camera	Description
1	Video System	4K30, 4K25, 1080P30, 1080P25
2	Sensor	1/1.8-inch, CMOS, Effective Pixel: 8.42M
3	Scanning Mode	Progressive
4	Lens	20x, f=4.4mm ~ 52.8mm, F1.8 ~ F2.6
5	Minimum Illumination	0.5 Lux @ (F1.8, AGC ON)
6	Shutter	1/30s ~ 1/10000s
7	White Balance	Auto, Indoor, Outdoor, One Push, Manual, VAR
8	Backlight Compensation	Supported
9	Digital Noise Reduction	2D&3D Digital Noise Reduction
10	SNR	≥55dB
11	Horizontal FOV	60.7° ~ 3.36°
12	Vertical FOV	41.1° ~ 1.89°
13	Pan Angle	±170°
14	Tilt Angle	-30° ~ +90°
15	Pan Speed	1.7° ~ 100°/s
16	Tilt Speed	1.7° ~ 69.9°/s
17	Image Flip	Supported
18	Image Freeze	Supported
19	Preset Position	255
20	Preset Accuracy	0.1°

No.	USB Features	
1	Operating System	Windows 7 and later, Mac OS X, Linux, Android
2	Color System/Compression	MJPEG/YUY2
3	Video Format	YUY2: 1080P@30fps (max.) MJPEG: 2160P@30fps (max.)
4	USB Audio	Supported
5	USB Protocol	UVC v1.1
6	UVC PTZ	Supported

No.	IPC Features	
1	Video Coding Standard	H.265/H.264/MJPEG
2	Video Stream	First Stream, Second Stream
3	First Stream Resolution	3840x2160, 1920x1080, 1280x720, 1024x576, 960x540, 640x480, 640x360
4	Second Stream Resolution	640x360, 480x270, 320x240, 320x180
5	Video Bit Rate	32kbps ~ 26624kbps
6	Rate Control	Variable Bit Rate, Fixed Bit Rate
7	Frame Rate	50Hz: 1fps ~ 25fps, 60Hz: 1fps ~ 30fps
8	Audio Compression Standard	AAC
9	Audio Bit Rate	96K, 128K, 256K
10	Supporting Protocols	TCP/IP, HTTP, RTSP, RTMP(S), DHCP, ONVIF, NTP and Multicast.

No.	Interfaces	
1	USB Interface	1 x USB3.0: Type-C
2	Video Interface	1 x USB2.0: Type-A
3	Network Interface	1 x HDMI 1.4b
		1 x LAN (POE): 10M/100M Adaptive Ethernet Port, support PoE
4	Audio Interface	1 x LINE IN: 3.5mm
5	MIC Interface	1 x MIC IN: 3.5mm
6	Communication Interface	1 x RS232 IN: 8pin min DIN; Max. Distance: 30m; Protocol: VISCA/Pelco-D/Pelco-P
		1 x RS232 OUT: 8pin min DIN; Max. Distance: 30m; Protocol: VISCA/Pelco-D/Pelco-P
		1 x RS485: 2pin phoenix port; Max. Distance: 1200m; Protocol: VISCA/Pelco-D/Pelco-P
7	Power Interface	JEITA type (DC IN 12V)



No.	General Specifications	
1	Input Voltage	DC 12V/PoE (802.3af)
2	Input Current	1.0A (max.)
3	Operating Temperature	0°C ~ 40°C
4	Storage Temperature	-40°C ~ 60°C
5	Power Consumption	12W (max.)
6	Dimension	240 x 143.8 x 171 (mm)
7	Net Weight	About 1.6Kg

 **Note:** Product features and specifications are subject to change without notice.

### 3.3 Interfaces and Buttons

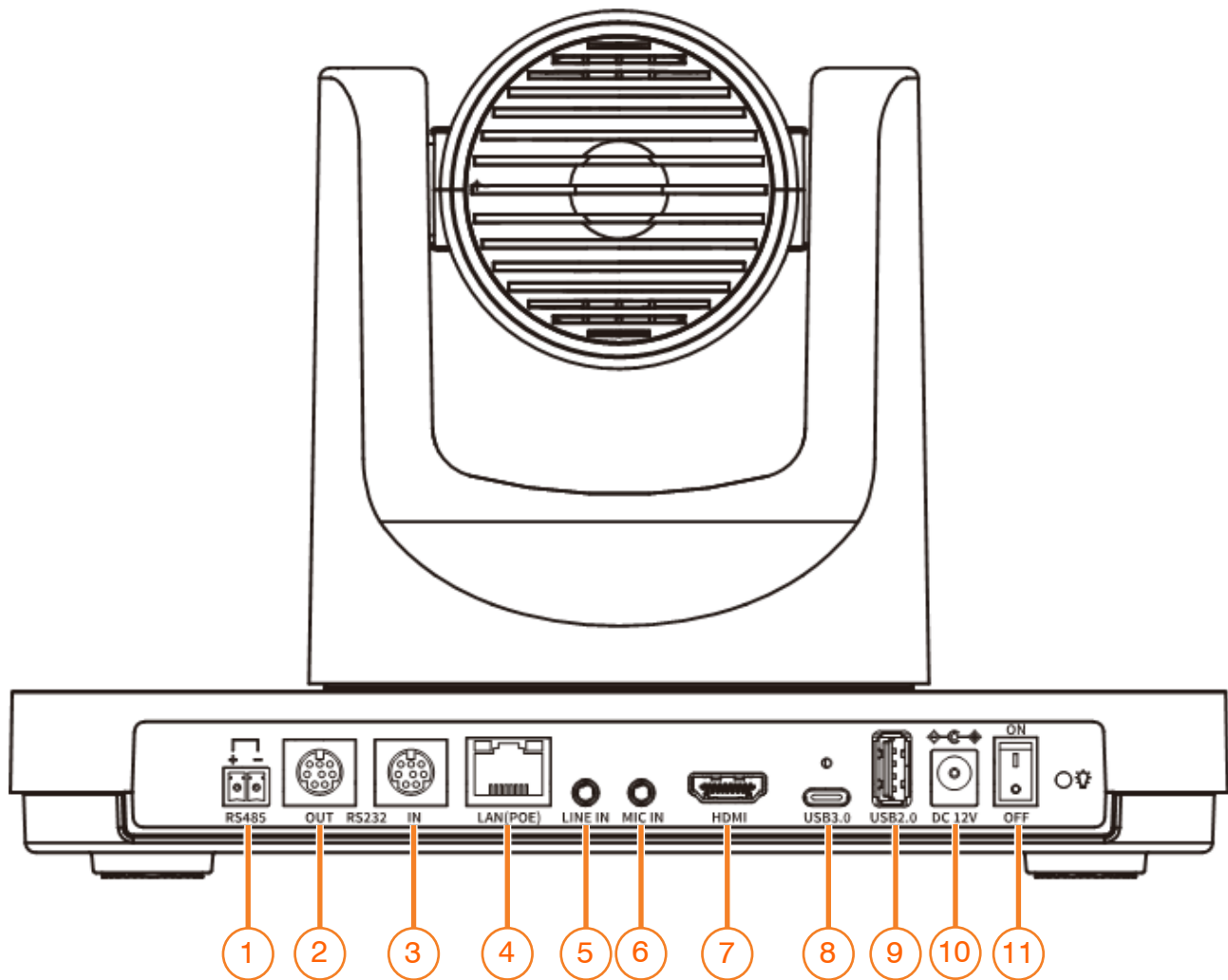

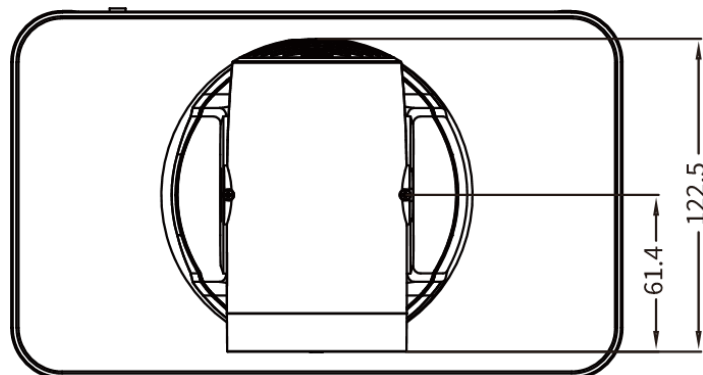
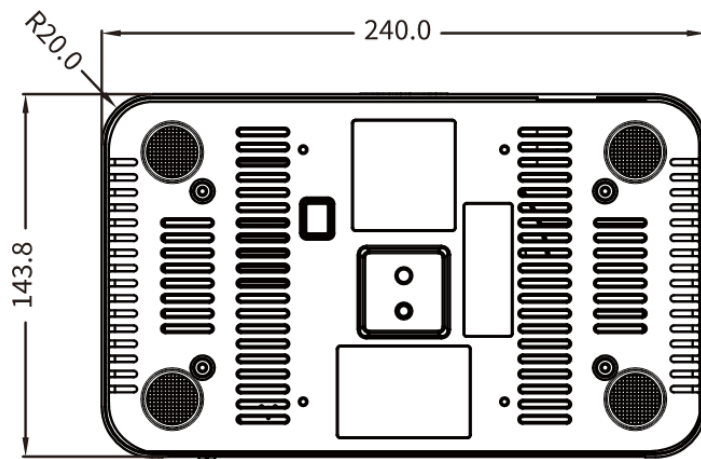
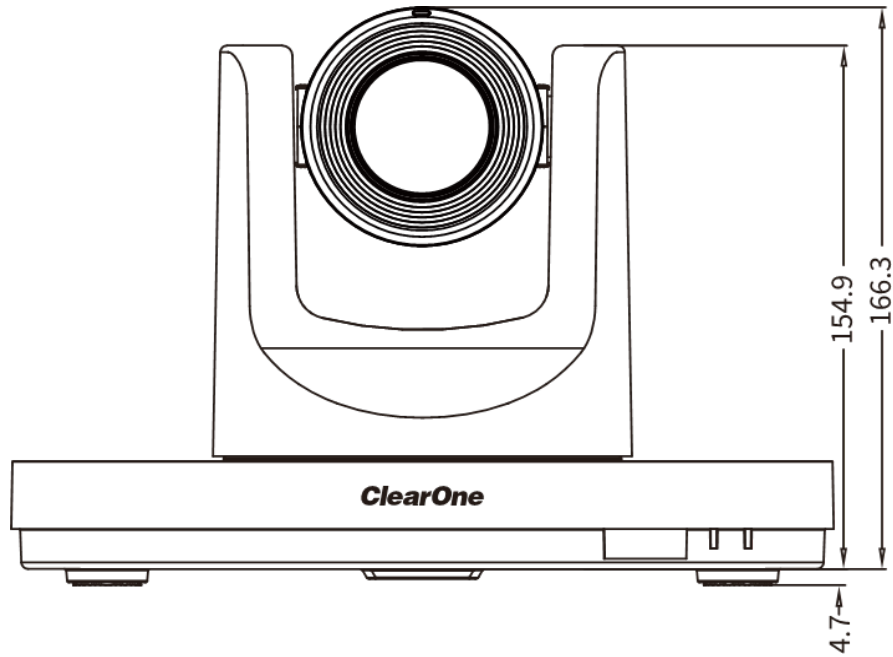

No.	Interface
1	RS485 Interface
2	RS232 OUT Interface
3	RS232 IN Interface
4	LAN (POE) Interface
5	LINE IN Interface
6	MIC IN Interface
7	HDMI Interface
8	USB3.0 Interface
9	USB2.0 Interface
10	DC 12V Interface
11	Power ON/OFF Button

3.4 Dimensions

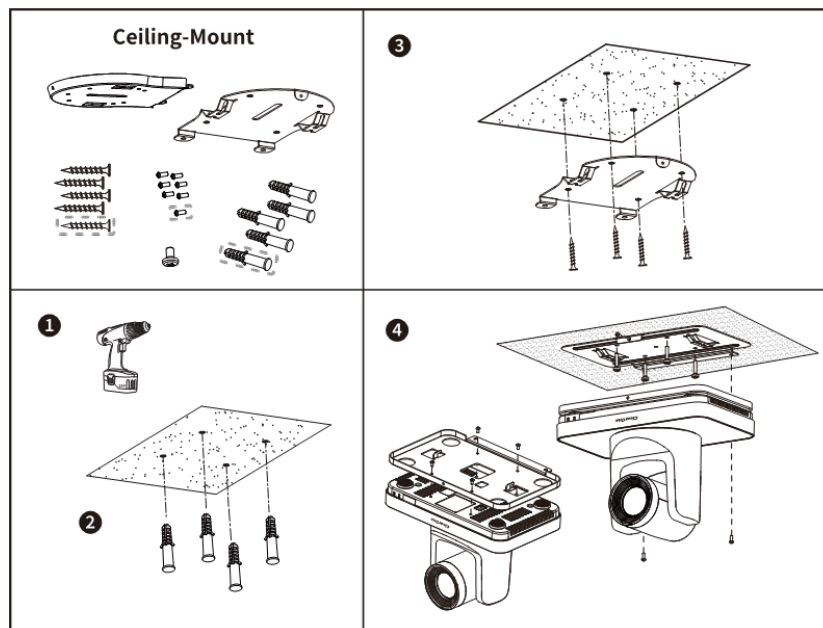
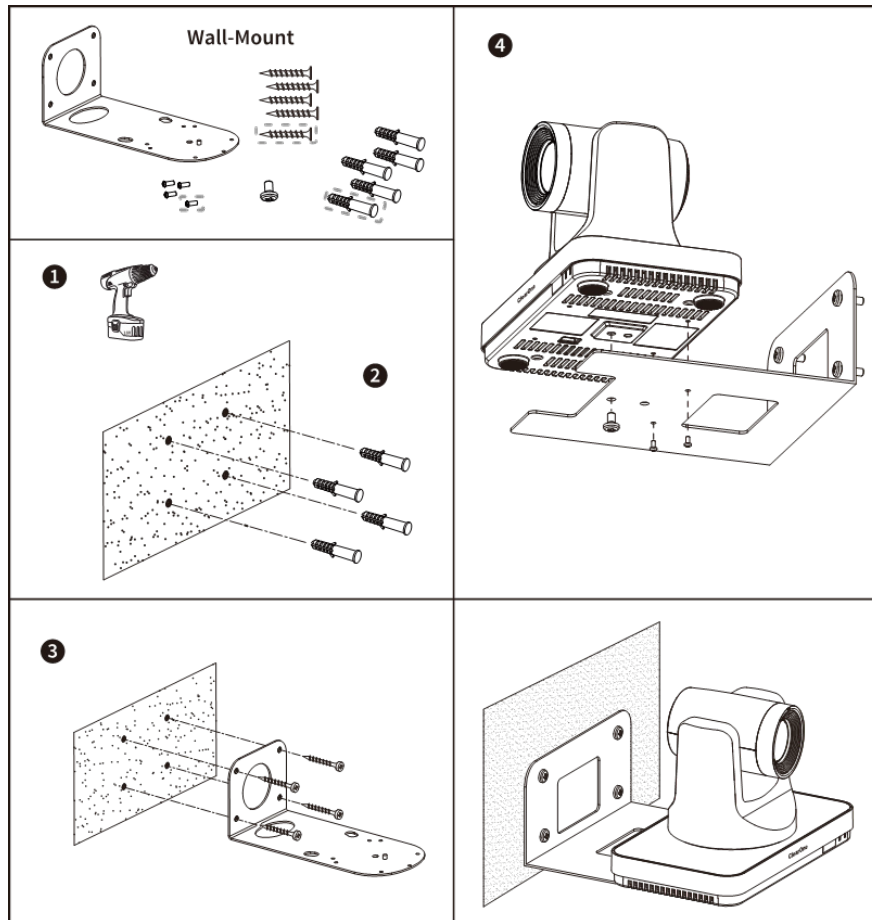

3.5 Installation



 **Note:** The installation diagram is for reference only. The brackets and screws are not standard. For packing accessories, please refer to the actual product.

## 3.6 Remote Control

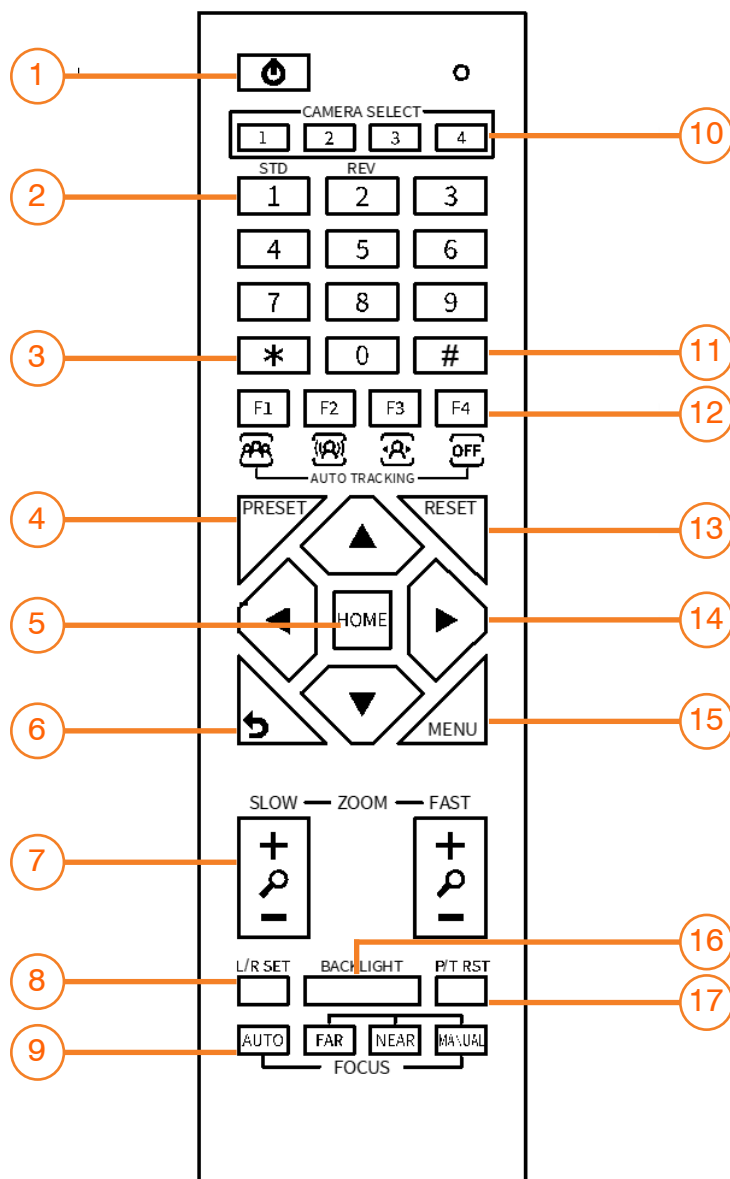
**Shortcut Set**

F1: Short press to open One Push Framing mode / Long press

2s to open Auto Framing mode

F3: Short press to open Auto Tracking mode

F4: Long press 2s to close Auto Framing or Auto

- Tracking mode/Short press to stop Auto
- Framing or Auto Tracking

[\*] + [#] + [1]: OSD menu default English

[\*] + [#] + [3]: OSD menu default Chinese

[\*] + [#] + [4]: Display current IP address

[\*] + [#] + [6]: Quickly recover the default

[\*] + [#] + [8]: Check the camera version

[\*] + [#] + [9]: Quickly set up inversion

[\*] + [#] + [MANUAL]: Restore to default IP address.

No.	Name	Function Description
1	Standby Key	Press to enter standby mode
2	Number Key	To set preset or call preset
3	*Key	Use with other keys
4	Preset Key	Preset: Setting Preset + Number key(0-9)
5	HOME Key	Confirm selection or press to turn PTZ back to the middle position
6	Return Key	Press to return to the previous menu
7	Zoom Key	<ul style="list-style-type: none"> <li>• SLOW: Zoom In [+] or Zoom Out [-] slowly</li> <li>• FAST: Zoom In [+] or Zoom Out [-] fast</li> </ul>
8	L/R Set Key	<ul style="list-style-type: none"> <li>• Standard: Simultaneously press L/R SET + 1</li> <li>• Reverse: Simultaneously press L/R SET + 2</li> </ul>
9	Focus Key	Auto/Manual/Far-end/Near-end focus
10	Camera Select Key	Press to select and control the camera
11	#Key	Use with other keys
12	IR Remote Control Key	[*] + [#] + [F1]: Address 1 [*] + [#] + [F2]: Address 2 [*] + [#] + [F3]: Address 3 [*] + [#] + [F4]: Address 4
13	Reset Key	Clear the preset position: [RESET] + Number key (0-9)
14	PTZ control keys	PTZ moved according to the arrow indicates
15	Menu Key	Enter or exit OSD MENU
16	Backlight Key	Backlight ON/OFF: Press repeatedly to enable or disable the backlight compensation. NOTE: <ul style="list-style-type: none"> <li>• Effective only in auto exposure mode.</li> <li>• If there is a light behind the subject that causes the subject to become dark, press the backlight key to enable backlight compensation. Press again to disable this function.</li> </ul>
17	P/T RST (PTZ Reset) Key	Press to preset Pan/Tilt self-test.

### Command List

The camera uses the VISCA/Pelco-D/Pelco-P serial standard. If you need VISCA/Pelco-D/Pelco-P protocol command list details, please contact ClearOne Technical Support.

## 4. GUI Settings

### 4.1 Menu

Press the [MENU] key to display the main menu on the screen. Use the arrow key to move the cursor to a desired item and press the [HOME] key to confirm and enter the corresponding sub-menu.

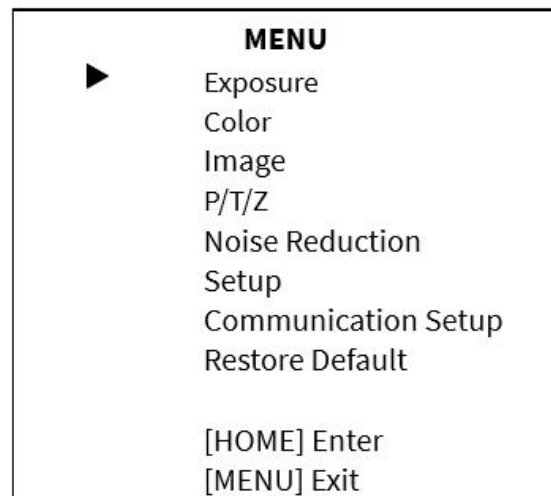

### 4.2 Exposure

When in the main menu page, move the cursor to the [Exposure] and press the [HOME] key to confirm and enter the Exposure page as shown here.

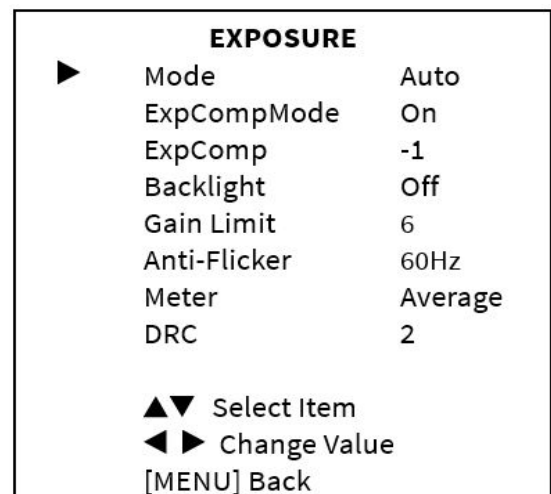

**Mode:** Auto, Manual, SAE, AAE, Bright.

**ExpCompMode:** (Exposure Compensation Mode): On, Off (Effective only in Auto mode).

**ExpComp:** (Exposure Compensation Value): -7 ~ +7 (Effective only in ExpCompMode On).

**Backlight:** On, Off (Effective only in Auto mode).

**Gain Limit:** 0 ~ 15 (Effective in Auto, SAE, AAE, Bright mode).

**Anti-Flicker:** Off, 50Hz, 60Hz (Effective in Auto, AAE, Bright mode).

**Meter:** Average, Center, Smart, Top (Effective in Auto, SAE, AAE, Bright mode).

**Iris:** F1.8, F2.0, F2.4, F2.8, F3.4, F4.0, F4.8, F5.6, F6.8, F8.0, F9.6, F11.0, Close (Effective in Manual, AAE mode).

**Shutter:** 1/30, 1/60, 1/90, 1/100, 1/125, 1/180, 1/250, 1/350, 1/500, 1/725, 1/1000, 1/1600, 1/2000, 1/3000, 1/4000, 1/6000, 1/10000 (Effective in Manual, SAE mode).

**Gain:** 0 ~ 7 (Effective only in Manual mode).

**Bright:** 0~17 (Effective only in Bright mode).

**DRC:** 0 ~ 8.

### 4.3 Color

When in the main menu page, move the cursor to the [Color] and press the [HOME] key to confirm and enter the Color page as shown here.

**WB-Mode:** (White Balance Mode): Auto, Indoor, Outdoor, One Push, Manual, VAR.

**RG Tuning:** (Red Gain Tuning): -10 ~ +10 (Effective in Auto, One Push, VAR mode).

**BG Tuning:** (Blue Gain Tuning): -10 ~ +10 (Effective in Auto, One Push, VAR mode).

**Saturation:** 60% ~ 200%.

**Hue:** 0 ~ 14.

**AWB Sens:** (The White Balance Sensitivity): Low, Middle, High (Effective in Auto, One Push mode).

**RG** (Red Gain): 0~255 (Effective in Manual mode).

**BG** (Blue Gain): 0~255 (Effective in Manual mode).

**Color Temp:** 2500K ~ 8000K (Effective only in VAR mode).

### 4.4 Image

When in the main menu page, move the cursor to the [Image] and press the [HOME] key to confirm and enter the Image page as shown here.

**Luminance:** 0 ~ 14.

**Contrast:** 0 ~ 14.

**Sharpness:** Auto, 0 ~ 15.

**Flip-H:** On, Off.

**Flip-V:** On, Off.

**B&W-Mode:** On, Off.

**Gamma:** Ext, Default, 0.45, 0.5, 0.56, 0.63.

**Style:** Norm, Clarity, Bright, CStyle.

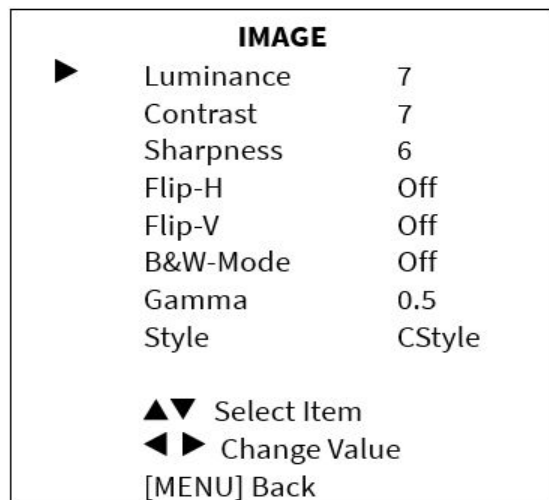
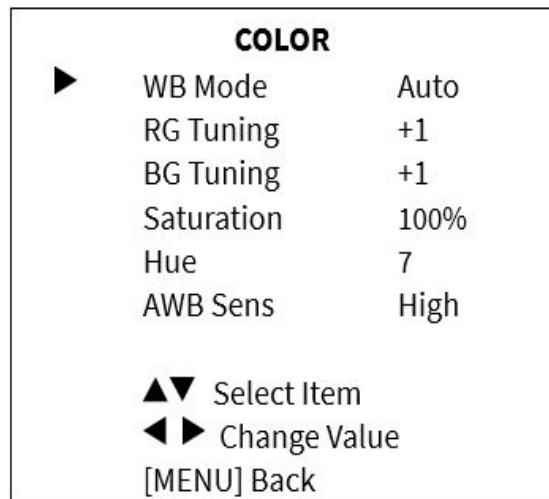



### 4.5 P/T/Z

When in the main menu page, move the cursor to the [P/T/Z] and press the [HOME] key to confirm and enter the P/T/Z page as shown here.

**Speed By Zoom** (The Depth of Field Ratio): On, Off.

**AF-Zone** (Auto Focus Area): Front, Top, Center, Bottom.

**AF-Sense** (Auto Focus Sensitivity): Low, Normal, High.

**Display Info:** On, Off.

**Call Preset Speed:** 1 ~ 24.

**Pre Zoom Speed:** 0 ~ 7.

P/T/Z		
▶	SpeedByZoom	On
	AF-Zone	Front
	AF-Sense	High
	Display Info	On
	Call Preset Speed	18
	Pre-Zoom Speed	5
▲▼ Select Item		
◀▶ Change Value		
[MENU] Back		

### 4.6 Noise Reduction

When in the main menu page, move the cursor to the [Noise Reduction] and press the [HOME] key to confirm and enter the Noise Reduction page as shown here.

**NR2D-Level** (2D Noise Reduction): Auto, Off, 1 ~ 5.

**NR3D-Level** (3D Noise Reduction): Auto, Off, 1 ~ 8.

NOISE REDUCTION		
▶	NR2D-Level	Auto
	NR3D-Level	Auto
▲▼ Select Item		
◀▶ Change Value		
[MENU] Back		

### 4.7 Setup

When in the main menu page, move the cursor to the [Setup] and press the [HOME] key to confirm and enter the Setup page as shown here.

**Language:** English, Chinese, Russian.

**Video Format:** 4K30, 4K25, 1080P30, 1080P25.

**USB Audio:** On, Off.

**Standby Mode:** On, Off.

**Wakeup Pos:** Pos0, Pos UVC (Effective only in Standby Mode On).

**UVC H264:** On, Off.

**Tally Mode:** On, Off.

**Track Mode:** Manual, Frame, Track.

SETUP		
▶	Language	EN
	Video Format	1080P30
	USB Audio	On
	Standby Mode	Off
	UVC H264	On
	Tally Mode	On
	Track Mode	Manual
▲▼ Select Item		
◀▶ Change Value		
[HOME] OK		
[MENU] Back		

 **Note:** The setting of USB Format, USB Mode and UVC H264 will take effect after press the [HOME] key to confirm to restart the device.

### 4.8 Communication Setup

When in the main menu page, move the cursor to the [Communication Setup] and press the [HOME] key to confirm and enter the Communication Setup page as shown here.

- Protocol:** Auto, VISCA, PELCO-D, PELCO-P.
- V\_Address:** 1 ~ 7 (Effective in Auto, VISCA protocol).
- V\_AddrFix:** On, Off (When set to On, the 88 30 01 FF command does not work. Effective in Auto, VISCA protocol).
- P\_D\_Address:** 0 ~ 254 (Effective in Auto, PELCO-D protocol).
- P\_P\_Address:** 0 ~ 31 (Effective in Auto, PELCO-P protocol).
- Net Mode:** Serial, Paral (Effective in Auto, VISCA protocol).
- Baudrate:** 2400, 4800, 9600, 38400.

**COMMUNICATION SETUP**

▶	Protocol	VISCA
	V_Address	1
	V_AddrFix	Off
	Net Mode	Serial
	Baudrate	9600

▲▼ Select Item  
 ◀▶ Change Value  
 [MENU] Back

### 4.9 Restore Default

When in the main menu page, move the cursor to the [Restore Default] and press the [HOME] key to confirm and enter the Restore Default page as shown here.

- Restore:** Yes, No.

**RESTORE DEFAULT**

▶	Restore?	No
---	----------	----

◀▶ Change Value  
 [HOME] OK  
 [MENU] Back

### Notice

When “Yes” is selected and confirmed with the [HOME] key, all parameters will be restored to their default values, including the IR Remote address and VISCA address.

 **Note:** GUI menu and parameters are subject to change without notice.

## 5. Web Settings

New features. Check your version

Unite 260 new features are only available with firmware versions 9.1.21 or higher.

To check your firmware version please:

Press [\*]+[#]+[8] or go to the camera website and check it under Information menu.

### 5.1 Access Camera

Access <http://192.168.19.8> to pop up the login window, then input username (default: admin) and password (default: admin). After login, it will show as:



This option is disabled by default. Only users with administrator credentials (as described in the previous point) can enable or disable it when a USB key is connected.

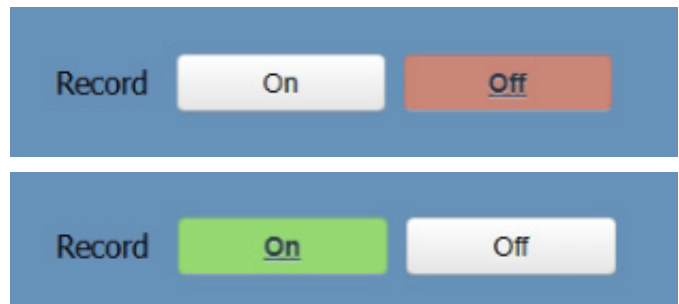

### 5.2 Control Camera

All pages include two menu bars:

Real Time Monitoring: Video image displaying with function buttons.

Parameter Setup: Parameter configuring.



#### A. Video Viewing Window

The video viewing window is same as video resolution, the bigger the resolution, the bigger the playing area. Double click the viewing window to show full screen, double click again, to return to initialized size.

Status bar in viewing window shown as below:

- 1) Video Pause: Click to pause the real-time video, click again to resume.
- 2) Audio Control: Click to adjust the volume or mute.
- 3) Full screen switch button.

## B. PTZ Setup

### 1) Pan and Tilt Control

The direction arrows and home button allow you to manually drive the camera to desired position.

### 2) Zoom

Zoom In and Zoom Out buttons allow for wide or narrow view of the space.

### 3) Focus

Focus In and Focus Out button allow for fine manual focus adjustment if the camera has any auto focusing problems on difficult object. rate can be set to 0 ~ 7.

### 4) PTZ Speeds

Pan speed rate can be set to 1 ~ 24, Tilt speed rate can be set to 1 ~ 20. Zoom and Focus speed rate can be set to 0 ~ 7.

### 5) PTZ Presets

When the PTZ turns to the position that you would like to return to later, you can set presets for quick recall.

Type a number (0 ~ 254) into the preset box and click “Set” button to save.

When the PTZ turn to other position, input the preset number and click “Call” button to turn the PTZ back to the preset position.

### 6) PTZ/OSD

Move the cursor to dropdown menu, select and click “OSD” to open the on-screen menu and do menu settings on the interface.

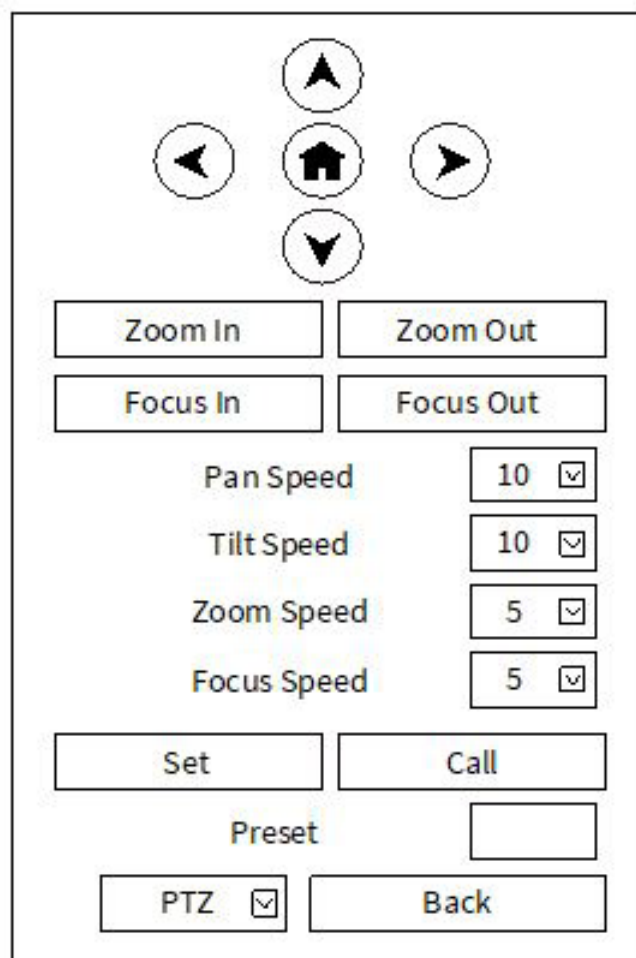

## C. Language Setting

Click to select “Simplified Chinese”, “English”, “Russian” or “Traditional Chinese” to change the language of the webpage.



## D. Focus Mode

Change Focus Mode between Auto and Manual.

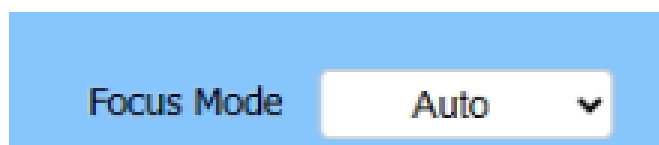

### 5.3 Video Setting

#### 1) Video Format

Support 50Hz (PAL) and 60Hz (NTSC) formats.

#### 2) Encode Level

Support baseline, main-profile and high-profile.

#### 3) Encode Codec

Support H264, H265 and MJPEG.

#### 4) Resolution

First stream support 3840x2160, 1920x1080, 1280x720, 1024x576, 960x540, 640x480, 640x360; Second stream support 640x360, 480x272, 320x240, 320x180. The bigger the resolution, the clearer the image, and the larger the code stream, the more network bandwidth will be taken.

#### 5) Bit Rate

You can specify the bit rate, the larger of the bit rate, the clearer of the image. The configuration of the bit rate needs to be combined with the network bandwidth. When the network bandwidth is narrow and the bit rate is configured larger, the video stream cannot be transmitted normally, and the visual effect will be worse.

#### 6) Frame Rate

You can specify the size of the frame rate, the greater the frame rate, the smoother the image, the smaller the frame, the more sense of beating.

#### 7) Key Frame Interval

Set the interval between two frames, the bigger the interval, the slower the response when opening the image for the first time.

#### 8) Bit Rate Control

Two modes for bit rate control:

CBR (Constant Bit Rate): Video coder will be coding according to the preset speed.

VBR (Variable Bit Rate): Video coder will adjust the speed based on preset speed to gain the best image quality.

#### 9) Slice Split Enable

Select to turn On/Off the Slice Split Enable function.

#### 10) Split Mode

Split Mode Fixed bytes.

#### 11) Slice Size

Size for slice.

**Video Settings**

Video Format

Encode Level

**First Stream**

Encode Codec

Resolution

Bit Rate

Frame Rate   fps

I Key Frame Interval

Bit Rate Control

Slice Split Enable

Split Mode

Slice Size  blocks/bytes

**Second Stream**

Encode Codec

Resolution

Bit Rate

Frame Rate   fps

I Key Frame Interval

Bit Rate Control

Slice Split Enable

Split Mode

Slice Size  blocks/bytes

### 5.4 Image Setting

**1) Brightness**

Image Bright: 0~14 (Default is 7).

**2) Saturation**

Image Saturation: 0~14 (Default is 4).

**3) Contrast**

Image Contrast: 0~14 (Default is 7).

**4) Sharpness**

Image sharpness: 0 ~ 16 (Default is 6).

**5) Hue**

Image Hue: 0~14 (Default is 7).

**6) Flip & Mirror**

Flip: Select to turn On/Off the Flip function.

Mirror: Select to turn On/Off the Mirror function.

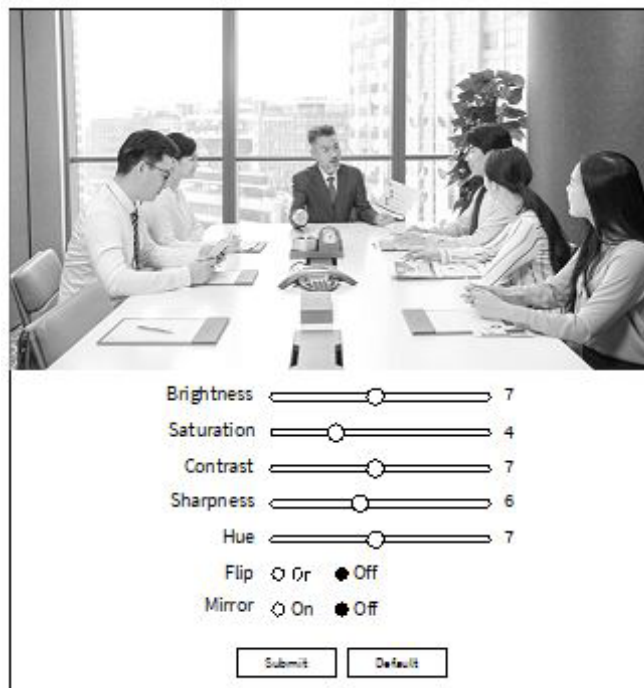

### 5.5 Audio Setting

**1) Audio Switch**

Select to turn On/Off the audio switch.

**2) Audio Type**

Audio type AAC.

**3) Sample Rate**

Sample rate 32K.

**4) Bit Rate**

Bit rate 96K, 128K and 256K selectable.

**5) Input Type**

Input type Line in.

**6) ADTS Options**

Options: On, Off.

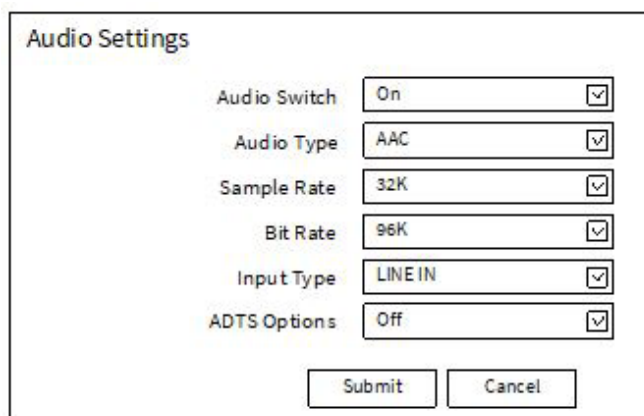

## 5.6 System Setting

### 1) Reboot

Click “Reboot” to restart system.

### 2) Username and Password

Modify the password of username and guest (use letters and Numbers only).

### 3) Record Settings

(\*Only firmware versions 9.1.21 or higher)

Packed Time(min) is the value that will define the maximum length of your recordings in minutes.

### 4) USB Flash Disk Information

With this option you can check the capacity of your USB Unit as well as mount/unmount it to use it, or even format it before using it.

## 5.7 Network Setting

### 1) Lan Settings

The default the IP address is 192.168.19.8, the MAC address cannot be modified.

### 2) Port Settings

#### A. HTTP Port

The IP address identifies a network device and multiple network programs can run on the device, each network program uses the network port for data transmission. The port setting on this page is to set up which port the WEB SERVER program uses to transmit. During port mapping, it needs to be consistent with the port number (default is 80).

#### B. RTSP Port

Set up the RTSP port, default is 554.

#### C. TCP Port

Set up the TCP port, default is 5678.

#### D. UDP Port

Set up the UDP port, default is 1259.

#### E. Sony Visca

Sony Visca 52381.

### 3) RTMP(S) Settings

Set the MRL of RTMP(S) and select “on”, “off”, “video” and “audio” functions to enable or disable video and audio in the two streams.

### 4) SRT Settings

Turn On/Off SRT and set up the SRT Mode, Sever, Port, Encryption, Password, Bandwidth Overhead, Variable Latency and StreamId.

### 5) RTSP Settings

Turn On/Off the RTSP Auth.

### 6) ONVIF Settings

Turn On/Off the ONVIF and ONVIF Auth.

### 7) Multicast Settings

Turn On/Off Multicast, set up the Multicast Address (default is 224.1.2.3) and Port (default is 6688; 6688 is the multicast port of first stream and 6690 is the multicast port of second stream).

### 8) NTP Settings

Turn On/Off NTP time sync, Main time show and Sub time show; select the Time Zone; set up the Server address, Time interval and the Time Show Position of the two streams.

**Lan Settings**

IP Configuration Type  Fixed IP Address

IP Address

Subnet Mask

Gateway

DNS Address

MAC Address

**Port Settings**

HTTP Port

RTSP Port

TCP Port

UDP Port

SonyVisca

**RTMP(S) Settings**

First Stream  On  Off  Video  Audio

MRL

Second Stream  On  Off  Video  Audio

MRL

**SRT Settings**

SRT  On  Off

SRT Mode

SRT Server

SRT Port

SRT Encryption

SRT Password

SRT Bandwidth Overhead

SRT Variable Latency

SRT StreamId

**RTSP Settings**

RTSP Auth  On  Off

**ONVIF Settings**

ONVIF  On  Off

ONVIF Auth  On  Off

**Multicast Settings**

Multicast  On  Off

Address

Port

**NTP Settings**

NTP Time Sync  On  Off

Time Zone

Server Address

Time Interval (min)

Main Time Show  On  Off

Position

Sub Time Show  On  Off

Position



### 5.8 AI (Only firmware versions 9.1.21 or higher)

From this menu the camera AI can be managed from 3 different areas:

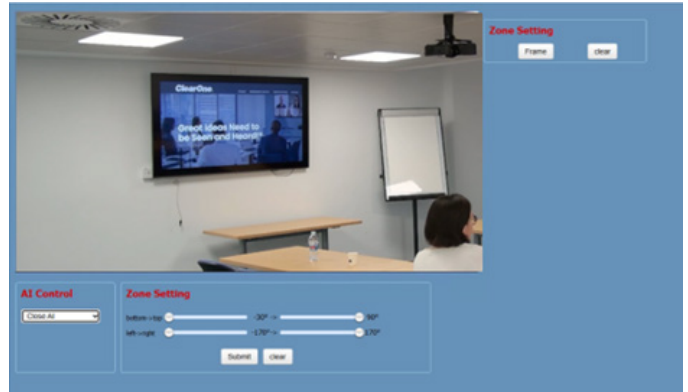

#### 1. AI Control

AI detection can be defined here, changing between Auto Framing, Single Tracking or disabling AI.

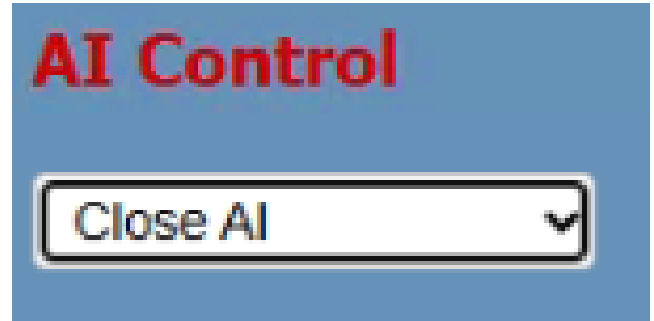

#### 2. Zone setting

Click on Frame to start defining your zone over the image, also thru Zone settings you can define the areas bottom to top as well as left to right.

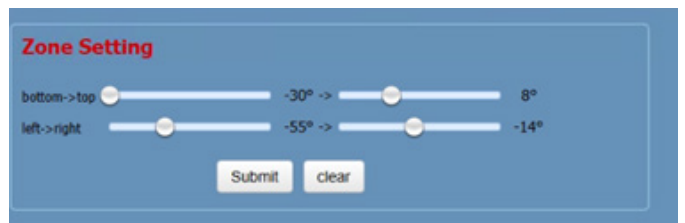
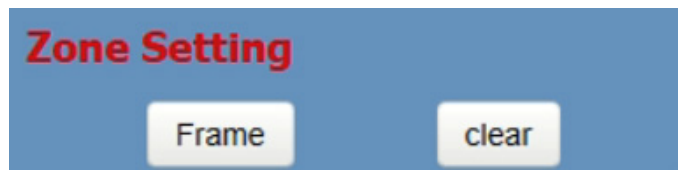

### 5.9 Download the Upgrade Program

If you need the camera upgrade program, please contact ClearOne technical support.

 **Note:** WEB interface and device information are subject to change without notice.

## 6. Recording Audio:

This section explains how to record audio along with your video recordings.

### Important Note:

- This camera does not have a built-in microphone.
- To capture audio, you will need to connect an external microphone or audio source like a DSP.

### Using an External Microphone:

#### 1. Microphone Compatibility:

- The camera supports electret condenser microphones.

#### 2. Microphone Connection:

- The camera has a 1 channel 3.5mm Tip-Ring-Sleeve (TRS) line jack microphone input port.
- Ensure your microphone uses a compatible plug type (TRS or Tip-Ring-Ring-Sleeve (TRRS) plugs).

### Using a Line-Level Audio Source:

#### 1. Audio Source Compatibility:

- The camera also features a line-in port for connecting external audio sources with stronger signals, such as mixers, audio players, and DSPs.

#### 2. Line-Level Connection:

- Use a standard line-in port 3.5mm TRS jack cable to connect your audio source.

To use your PC/laptop's audio through the Unite 260 Pro's USB connection, follow these steps:

1. Using the remote control, navigate to MENU > SETUP.
2. Select USB Audio and set it to "On".
3. Your PC/laptop should now recognize the Unite 260 Pro as an microphone device.

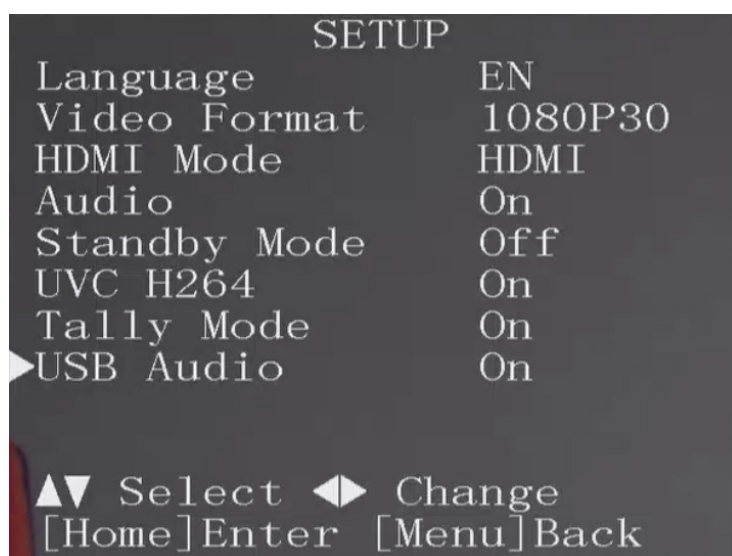

## 7. Serial Command Control

In default working mode, the camera can be controlled via RS-232 or RS-485 (half-duplex mode). The parameters are as follows:

- Baud rate: 2400/4800/9600 bits
- Start bit: 1 bit
- Data bit: 8 bits
- Stop bit: 1bit
- Parity bit: none

The process of initialization is complete when the camera pan-tilt rotates to the maximum position of top right and then returns to the center.

 **Note:** If the position preset 0 has been stored, the position preset 0 is called up after initialization, and users can control the camera with commands in the following command list.

### Network Configuration

#### Network Configuration

With VISCA

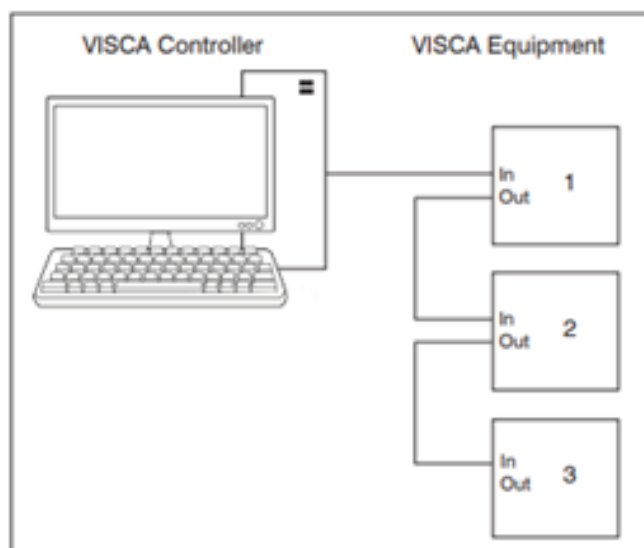

With Pelco

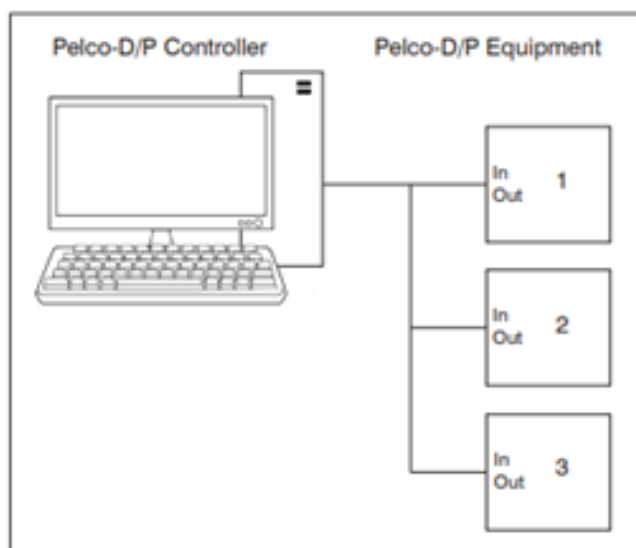

Control Interface Definition

Pin Number	Function
1	DTR
2	DSR
3	TXD
4	GND
5	RXD
6	RS485-
7	IR OUT
8	RS485+

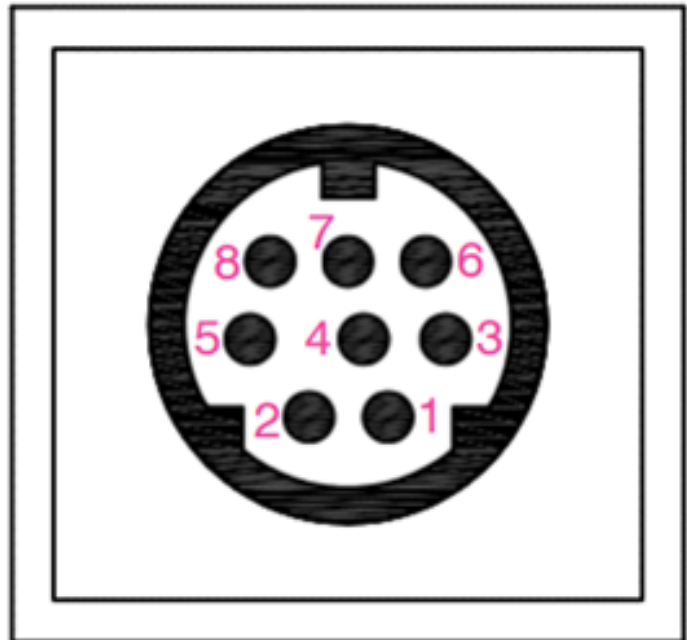

Camera	DB - 9 Serial
1. DTR	1. CD
2. DSR	2. RXD
3. TXD	3. TXD
4. GND	4. DTR
5. RXD	5. GND
6. RS485-	6. DSR
7. IR OUT	7. RTS
8. RS485+	8. CTS
	9. RI

Camera In	Camera Out
1. DTR	1. DTR
2. DSR	2. DSR
3. TXD	3. TXD
4. GND	4. GND
5. RXD	5. RXD
6. RS485-	6. GND
7. IR OUT	7. NC
8. RS485+	8. NC

## 8. Troubleshooting

### Image

- **The monitor shows no image**
  - 1) Ensure that the power supply of camera is connected, the voltage is normal, and the power indicator is always on.
  - 2) Turn off the power switch to check that the camera is self-testing.
  - 3) Ensure that the cable of video platform and TV is in correct connection.
- **Image jitters after the camera is properly connected**
  - 1) Ensure that the camera installation position is stable.
  - 2) Check that any vibrating machinery or object near the camera.
- **There is no video image in browser**

IE browser does not support HTML5, you need to use VLC plug-in to view videos. Please access VLC website (<http://www.videolan.org/vlc>) to download and install the 32-bit VLC media player, after installation, the video image will be displayed normally when access the camera. Other mainstream browsers already support HTML5 and do not need to install the VLC plug-in.
- **Unable to access through the browser**
  - 1) Using PC to access the network to test that the network access can work properly to eliminate the network fault caused by cable and PC virus until the PC and camera can ping each other.
  - 2) Disconnect the network, connect camera with PC separately and reset the IP address of PC if necessary.
  - 3) Ensure that the IP address, subnet mask and gateway settings is correct.
  - 4) Check that the MAC address is conflicts.
  - 5) Check that the web port is modified, the default setting is 80.

- **Forget the IP address or login password**

The default IP address is: 192.168.19.8; the default username and password are: admin.

### Control

- **Remote control does not work**
  - 1) Check and replace with new batteries.
  - 2) Ensure that the camera's working mode is correct.
  - 3) Ensure that the address key of remote control can match the camera.
- **Serial port cannot control**
  - 1) Ensure that the protocol, address and bit rate of the camera are consistent.
  - 2) Ensure that the control cable is properly connected.